



VFC Radiant & Convector Fire Range

With upgradeable control valve

Instructions for Use, Installation and Servicing

For use in GB, IE (Great Britain and Eire)

This appliance has been certified for use in countries other than those stated. To install this appliance in these countries, it is essential to obtain the translated instructions and in some cases the appliance will require modification. Contact Gazco for further information.

IMPORTANT

The chimney must be swept before installation. Do not attempt to burn rubbish on this fire. This fire has a naked flame. A suitable guard should be used for the protection of young children, the elderly or infirm

Please read these instructions carefully and keep them in a safe place. They will be needed when servicing the fire.

The commissioning sheet found in these instructions should be completed by the installer.

CONTENTS

	PAGE
Commissioning Check List	3
USER INSTRUCTIONS	4
INSTALLATION INSTRUCTIONS	
Technical Specifications	8
Site Requirements	9
Installation	11
Commissioning	16
SERVICING INSTRUCTIONS	
Servicing Requirements	17
Fault Finding	18
How to replace parts	19
Basic spare parts list	22

APPLIANCE COMMISSIONING CHECKLIST

IMPORTANT NOTICE

Explain the operation of the appliance to the end user, hand the completed instructions to them for safe keeping, as the information will be required when making any guaranteed claims.

FLUE CHECK	PASS	FAIL
1. Flue is correct for appliance		
2. Flue flow test		
3. Spillage test		
GAS CHECK		
1. Gas soundness & let by test		
2. Standing pressure test	mb	
3. Appliance working pressure (on High Setting) NB All other gas appliances must be operating on full	mb	
4. Gas rate	m ³ /h	
5. Does ventilation meet appliance requirements		
6. Have controls been upgraded (Upgradeable models only)	8455 Standard	YES NO

DEALER AND INSTALLER INFORMATION

Dealer.....

.....

.....

Contact No.....

Date of Purchase.....

Model No.....

Serial No.....

Gas Type.....

Installation Company.....

.....

.....

Engineer.....

Contact No.....

Corgi Reg No.....

Date of Installation.....

This product is guaranteed for 2 years from the date of installation, as set out in the terms and conditions of sale between Gazco and your local Gazco dealer. **This guarantee will be invalid, to the extent permitted by law, if the above Appliance Commissioning Checklist is not fully completed by the installer and available for inspection by a Gazco engineer.** The guarantee will only be valid during the second year, to the extent permitted by law, if the annual service recommended in the Instructions for Use has been completed by a Corgi registered engineer, and a copy of the service visit report is available for inspection by a Gazco engineer.

USER INSTRUCTIONS

1. GENERAL

- 1.1 Installation and servicing must only be carried out by a competent person.
- 1.2 In your own interest, and those of safety, this appliance must be installed by a competent person in accordance with local and national codes of practice. Failure to install the appliance correctly could lead to prosecution.
- 1.3 In all correspondence, please quote the appliance type and serial number which can be found on the databadge.
- 1.4 Ensure that curtains are not positioned above the fire and that there is a 300mm minimum clearance between the sides of the fire and any curtains.
- 1.5 This product is guaranteed for 2 years from the date of installation, as set out in the terms and conditions of sale between Gazco and your local Gazco dealer. Please consult with your local Gazco dealer if you have any questions. In all correspondence always quote the model No and serial No.

2. LIGHTING THE FIRE

- 2.1 Locate the control valve on the appliance. There are two control knobs on the valve: the right hand knob controls the pilot ignition and the left hand knob controls the main burner.
- 2.2 If your appliance has already been upgraded to battery remote control, please refer to the instructions provided with the upgrade to operate the remote control. The following instructions will work for either situation.

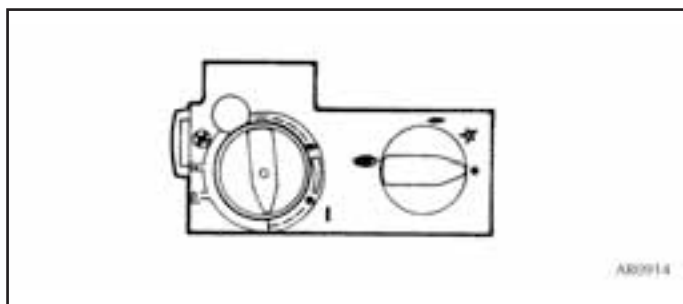

- 2.3 Ensure that the left-hand control knob is pointing to off (●).
- 2.4 Ensure that the right hand control knob is pointing to off (●).
- 2.5 Press in the right hand control knob and rotate it anti-clockwise until a click is heard (keep pressing in) and the knob is pointing to pilot (←). The pilot should now light. If the pilot has not lit, repeat the procedure until it does.
- 2.6 Keep the control knob pressed for 10 seconds and then release it. The pilot should stay alight. If the pilot goes out, repeat the procedures until it lights.
- 2.7 If the pilot will not light after repeated attempts, contact the retailer or installer from whom the appliance was purchased.
- 2.8 Turn the right hand control to point to main burner (↗). The appliance can now be controlled using the left hand control knob.

- 2.9 Turn the left hand control knob to point to low fire (↖), the main burner will light on low. The burner can now be controlled between low and high settings. Turn the control knob anticlockwise increase the flame height and clockwise to decrease the flame height.
- 2.10 The flames can be varied from blue to a yellow effect by moving the aeration lever to the desired position. See diagram 1.

THE YELLOW FLAMES WILL APPEAR WHEN THE FIRE HAS GAINED SUFFICIENT HEAT - TYPICALLY 10 TO 20 MINUTES.

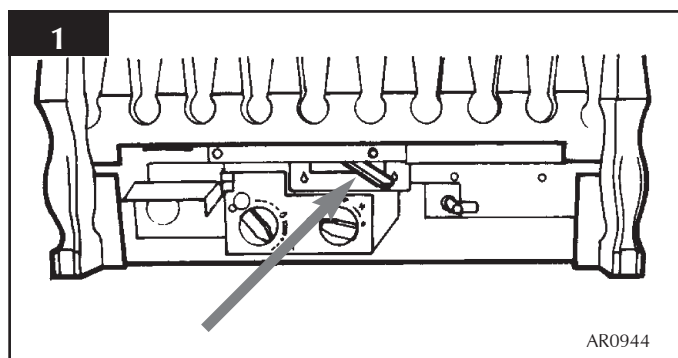

3. TURNING THE FIRE OFF

- 3.1 To turn the fire off, locate the control valve, turn the left-hand control knob until it points to off (●). The main burner will go out leaving the pilot burning.
- 3.2 To turn the pilot off, locate the control valve, turn the right hand control knob until it points to off (●). The pilot will go out.

4. LIGHTING THE FIRE WITH A MATCH

If the pilot does not ignite as described in Section 2:

- 4.1 Press in the right hand control knob and rotate it anti-clockwise until a click is heard (keep pressing in) and the knob is pointing to pilot (←), apply a lighted match to the pilot hood, see diagram 2.



USER INSTRUCTIONS

5. UPGRADING YOUR FIRE

- 5.1 Your fire is fitted with a control valve that can easily be upgraded to battery powered remote control. This upgrade can be fitted by anyone capable of simple DIY jobs and requires no special training. This upgrade can be obtained through your local Gazco stockist.
- 5.2 **STANDARD REMOTE CONTROL** This remote control can control the fire after the pilot has been lit. It can turn the main burner on and regulate it from low through to high and back again. It can turn the main burner off leaving the pilot burning **GAZCO PART NUMBER 8455**.
- 5.3 **IMPORTANT** - there is a thermostatic version of the upgrade but this is **NOT SUITABLE** for open flame fires like the VFC.

6. CLEANING THE FIRE

- 6.1 Remove the ceramic coals and place on a dry, clean surface. Remove the front coal ceramic, please handle with care.
- 6.2 The ceramic parts should not require cleaning. Do not use a vacuum cleaner or brush to clean these parts, any large pieces of debris may be removed by hand.
- 6.3 Ensure any debris is removed from the burner ports.
- 6.4 Replace the ceramics by referring to Section 7.

7. ARRANGEMENT OF FUEL BED COMPONENTS

ADVICE ON HANDLING AND DISPOSAL OF FIRE CERAMICS

The fuel effect and side panels in this appliance are made from Refractory Ceramic Fibre (RCF), a material which is commonly used for this application.

Protective clothing is not required when handling these articles, but we recommend you follow normal hygiene rules of not smoking, eating or drinking in the work area and always wash your hands before eating or drinking.

To ensure that the release of RCF fibres are kept to a minimum, during installation and servicing a HEPA filtered vacuum is recommended to remove any dust accumulated in and around the appliance before and after working on it. When servicing the appliance it is recommended that the replaced items are not broken up, but are sealed within heavy duty polythene bags and labelled as RCF waste.

RCF waste is classed as stable, non-reactive hazardous waste and may be disposed of at a licensed landfill site.

Excessive exposure to these materials may cause temporary irritation to eyes, skin and respiratory tract; wash hands thoroughly after handling the material.

NOTE: CERAMIC PARTS ARE FRAGILE. ONLY USE THE SPECIAL CERAMIC COALS SUPPLIED BY GAZCO - DO NOT USE REAL COALS.

- 7.1 Position the flame baffle on the rear of the tray. See diagram 3 arrow B.

- 7.2 Position the front coal, make sure it sits flat onto the burner skin. See diagram 3 arrow C.

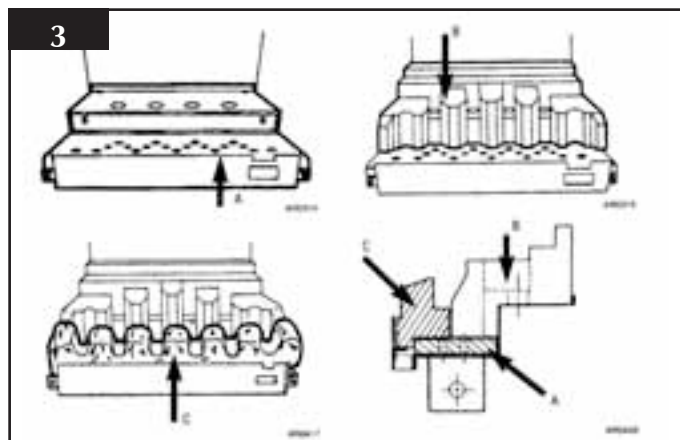

- 7.3 Place the coals following the appropriate diagrams and instructions

16" AND REDUCED DRAUGHT COAL LAYOUT

- 7.4 Curved fronts (Holyrood and Richmond) -place 5 large coals onto the front coal moulding ensuring that they rest against the front, place 2 small coals on to the front coal, 1 at each end. See diagram 4.

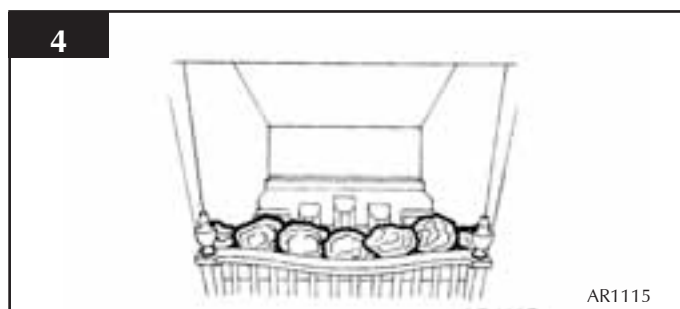

- 7.5 Flat fronts (All others) - Place 3 large coals and 4 small coals onto the front coal moulding ensuring that they rest against the decorative front, these should run intermittently small, large, small etc. See diagram 5.

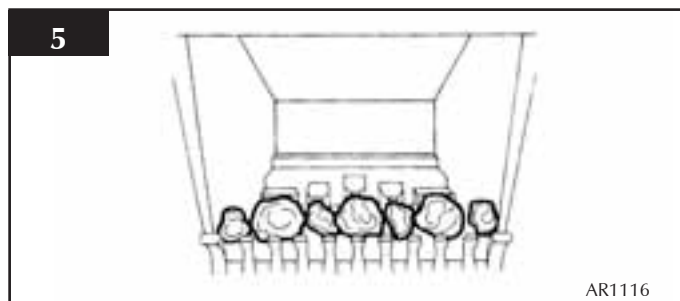

- 7.6 Place 5 large coals onto the flame baffle fingers. See diagram 6.

USER INSTRUCTIONS

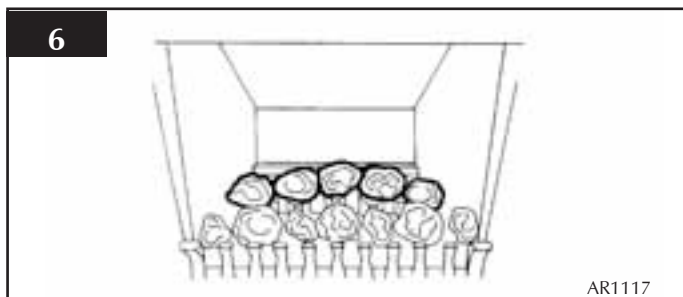

AR1117

7.7 Place 4 large coals so that they form a bridge between the other 2 rows, and 2 small coals, 1 at each end. Place 4 large coals at the back of the fire. See diagram 7.

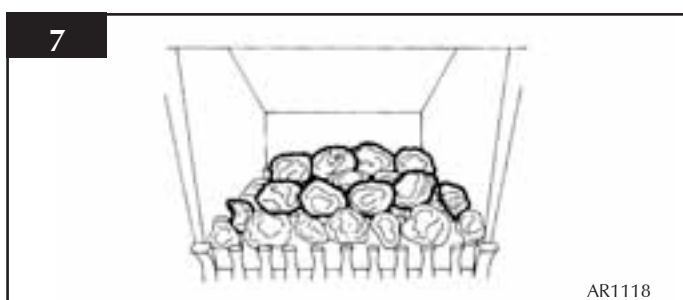

AR1118

7.8 Place the remaining 4 small coals on top of the others so that they form a bridge between the second and third rows. See diagram 8.

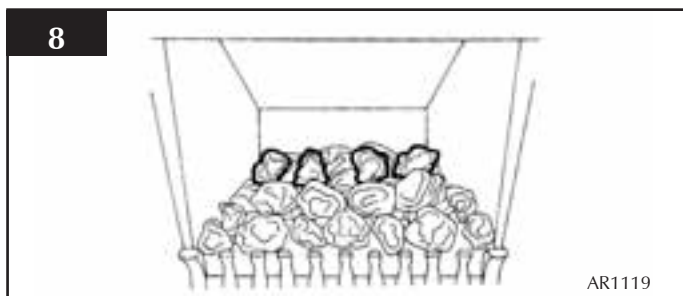

AR1119

18" COAL LAYOUT

7.9 Curved fronts (Holyrood) - place 6 large coals onto the front coal moulding ensuring that they rest against the front, place 2 small coals on to the front coal, 1 at each end. See diagram 9.

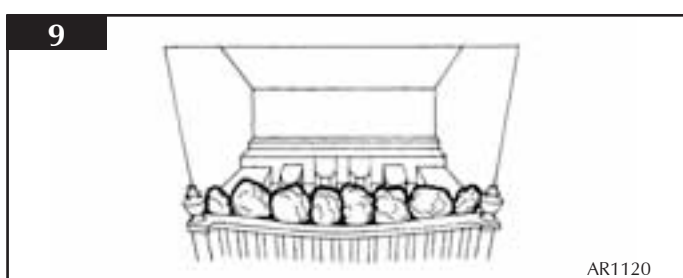

AR1120

7.10 Flat fronts (All others) - Place 4 large coals and 4 small coals onto the front coal moulding ensuring that they rest against the decorative front, these should run intermittently small, large, small, with 2 large in the centre. See diagram 10.

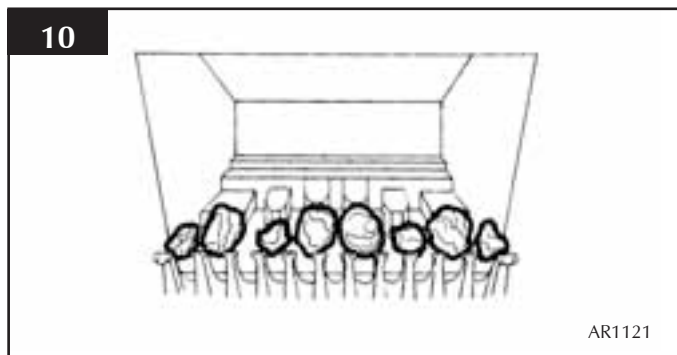

AR1121

7.11 Place 6 large coals onto the flame baffle fingers. See diagram 11.

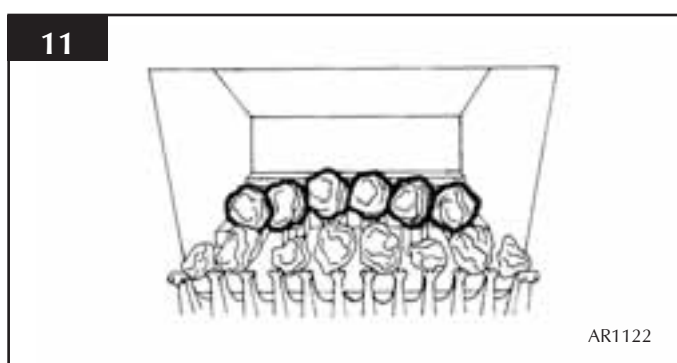

AR1122

7.12 Place 5 large coals so that they form a bridge between the other 2 rows, and 2 small coals, 1 at each end. Place 5 large coals at the back of the fire. See diagram 12.

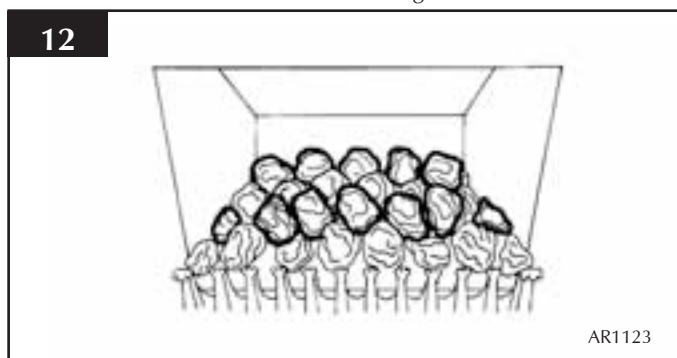

AR1123

7.13 Place the remaining 5 small coals on top of the others so that they form a bridge between the second and third rows. See diagram 13.

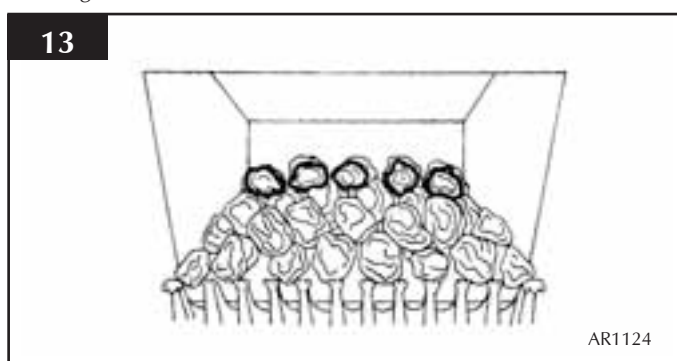

AR1124

USER INSTRUCTIONS

22" COAL LAYOUT

7.14 All fronts - place 8 large coals onto the front coal moulding ensuring that they rest against the front, place 2 small coals on to the front coal, 1 at each end. See diagram 14.

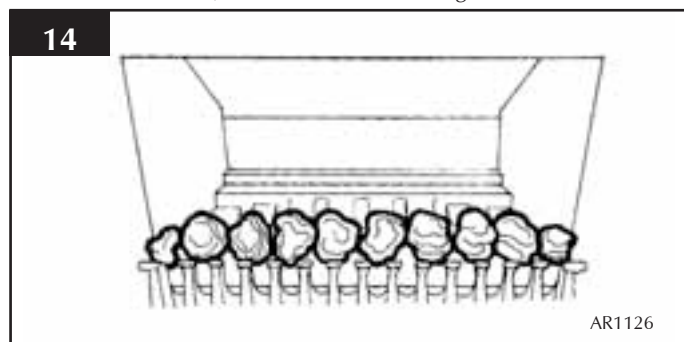

7.15 Place 8 large coals onto the flame baffle fingers. See diagram 15.

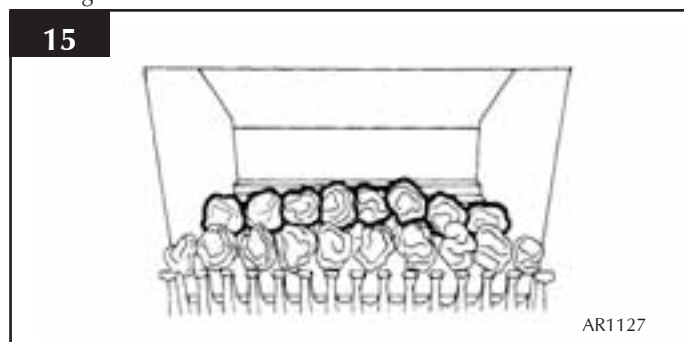

7.16 Place 7 large coals so that they form a bridge between the other 2 rows, and 2 small coals, 1 at each end. Place 6 large coals at the back of the fire. See diagram 16.

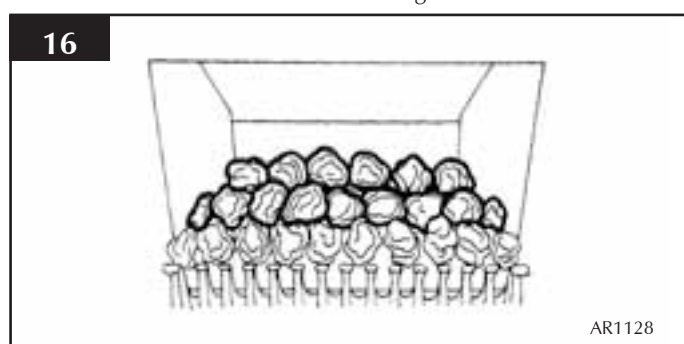

7.17 Place the remaining 6 small coals on top of the others so that they form a bridge between the second and third rows. See diagram 17.

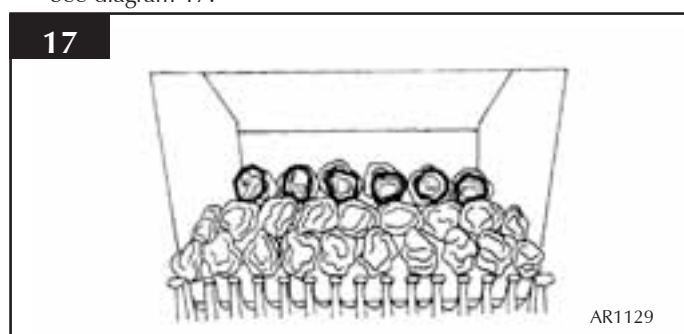

8. OXYGEN DEPLETION SENSOR

The appliance is fitted with an oxygen sensitive pilot system will act to cut off the gas supply to the fire should the oxygen in the room fall below its normal level. If the fire is turned off by this device, it usually indicates that there is a problem with the flue system, and this should be inspected by a qualified engineer.

Do not attempt to use the fire until an engineer says it is safe to do so.

This device is not a substitute for an independently mounted carbon monoxide detector.

9. THE FLAME FAILURE DEVICE

This is a safety feature incorporated in all GAZCO fires which automatically switches off the gas supply if the pilot light goes out and fails to heat the thermocouple.

10. 'RUNNING IN'

The surface coating on the coals used in your GAZCO fire will 'burn off' during the first few hours of use, producing a harmless and temporary odour. This will disappear after a short period of use. If the odour persists, ask your installer for advice.

11. SERVICING

This fire must be serviced every 12 months by a qualified Gas Engineer. In all correspondence, always quote the appliance type and serial number, which may be found on the databadge, adjacent to the control knob.

12. VENTILATION

Any purpose provided ventilation should be checked periodically to ensure that it is free from obstruction.

13. INSTALLATION DETAILS

To assist in any future correspondence, your retailer should have completed this commissioning sheet, this records, the essential installation details of the appliance. In all correspondence always quote the model No and serial No.

TECHNICAL SPECIFICATION

THESE INSTRUCTIONS COVER THE FOLLOWING MODELS:

VFC RADIANT	VFC COVECTOR	VFC LOW CONVECTOR
8300UC 16"	8420UC 16"	8461UC 16"LL
P8300UC 16"	P8420UC 16"	P8461UC 16"LL
8301UC 16"RD	8421UC 16"RD	8463UC 16"RD LL
P8301UC 16"RD	P8421UC 16"RD	P8463UC 16"RD LL
8305UC 18"	8425UC 18"	8466UC 18"LL
P8305UC 18"	P8425UC 18"	P8466UC 18"LL
8310UC 22"	8430UC 22"	8471UC 22"LL
P8310UC 22"	P8430UC 22"	P8471UC 22"LL

Model	Gas CAT.	Gas Type	Working Pressure	Aeration	Injector	Gas Rate m ³ /h	Input kW (Gross)		Country
							High	Max Flue Temp.	
16 RD	l ₂ H	Natural(G20)	20mbar	12N	400	•653	6.85	160°C	GB,IE
	l ₃ +	Butane(G30)	29mbar	RDL	180	•190	6.65		GB,IE
		Propane(G31)	37mbar			•250			
16	l ₂ H	Natural(G20)	20mbar	12N	600	•900	9.45	190°C	GB,IE
	l ₃ +	Butane(G30)	29mbar	9L	260	•272	9.50		GB,IE
		Propane(G31)	37mbar			•358			
18	l ₂ H	Natural(G20)	20mbar	11N	700	1•010	10.60	200°C	GB,IE
	l ₃ +	Butane(G30)	29mbar	9L	300	•303	10.60		GB,IE
		Propane(G31)	37mbar			•399			
22	l ₂ H	Natural(G20)	20mbar	9N	850	1•172	12.30	210°C	GB,IE
	l ₃ +	Butane(G30)	29mbar	0L	360	•363	12.70		GB,IE
		Propane(G31)	37mbar			•478			

MINIMUM FLUE SIZE 178mm (7")
 INLET CONNECTION SIZE 8mm
 MIN FLUE SPECIFICATION T260/N2/0/D/1

INSTALLATION INSTRUCTIONS

SITE REQUIREMENTS

The flue must be installed in accordance with all local and national regulation and the current rules in force.

1. FLUE AND CHIMNEY REQUIREMENTS

- 1.1 The chimney or flue system must comply with the rules in force, and must be a minimum of 178mm (7") in diameter.
- 1.2 The minimum effective height of the flue or chimney must be 3 m (10ft).
- 1.3 The chimney or flue must be free from any obstruction. Any damper plates should be removed or secured in the fully open position, and no restrictor plates should be fitted.
- 1.4 The chimney should be swept immediately prior to the installation of the appliance - unless it can be seen to be clean and unobstructed throughout its entire length.
- 1.5 Ensure that there is a smooth taper transition from the fireplace opening into the chimney or flue.
- 1.6 The flue pull should be checked prior to installation of the appliance. Apply a smoke pellet to the flue or chimney opening and ensure that the smoke is drawn into the opening. If there is not a definite flow, pre-heat the chimney for a few minutes and re-test the flow.

IF THERE IS STILL NO DEFINITE FLOW, THE CHIMNEY MAY REQUIRE ATTENTION- SEEK EXPERT ADVICE.

2. INSTALLATION OF THE GAS SUPPLY

- 2.1 Before installation, ensure that the local distribution conditions (identification of the type of gas and pressure) and the adjustment of the appliance are compatible.
- 2.2 Ensure that the gas supply is capable of delivering the required amount of gas, and is in accordance with the rules in force.
- 2.3 Soft copper tubing and soft soldered joints can be used but must not be closer than 50mm (2") to the underside of the firebox.
- 2.4 A means of isolating the gas supply to the appliance must be provided independent of any appliance control.
- 2.5 All supply gas pipes must be purged of any debris that may have entered, prior to connection to the appliance.

3. VENTILATION

It is important to ensure that any national ventilation requirements are taken into account during the installation of this appliance.

- 3.1 Ventilation requirements differ according to the model. Minimum permanent effective free air requirements - if this is the sole gas appliance in the room - are as follows:

Model No.	Description	Min. vent cm2
8300UC, P8300UC 8305UC, P8305UC 8310UC, P8310UC	16" VFC Radiant 18" VFC Radiant 22" VFC Radiant	100 See note b.
8301UC, P8301UC	RD VFC Radiant	NONE
8421UC, P8421UC 8463UC, P8463UC	RD VFC Convector	NONE See notes a & b
8420UC, P8420UC 8461UC, P8461UC	16" VFC Convector	15
8425UC, P8425UC 8466UC, P8466UC	18" VFC Convector	20
8430UC, P8430UC 8471UC, P8471UC	22" VFC Convector	30 See note b

Note a:

Gas input is less than 7kW and flue products clearance under 70 m³/hr. Some countries call for 100cm² ventilation. Check local standards.

Note b:

It is essential to check for flue clearance (see diagrams 17/18) If spillage is detected, it may be necessary to provide additional ventilation.

- 3.2 The above table is in addition to any openable window, and although it must communicate with the outside air, wherever possible, it can communicate with an adjacent room provided that the space has a similar vent to the outside.

AIR VENTS MUST NOT BE RESTRICTED.

4. APPLIANCE LOCATION

- 4.1 This appliance must stand on a non-combustible hearth that is at least 12mm thick.
- 4.2 It must be fitted into a non-combustible opening.
- 4.3 These appliances must be hearth mounted into a fireplace opening conforming to National Standards. The minimum dimensions shall be as shown in diagram 1A for VFC Radiant fires or diagram 1B for VFC Convective fires. (The shaded area must be flat and square).

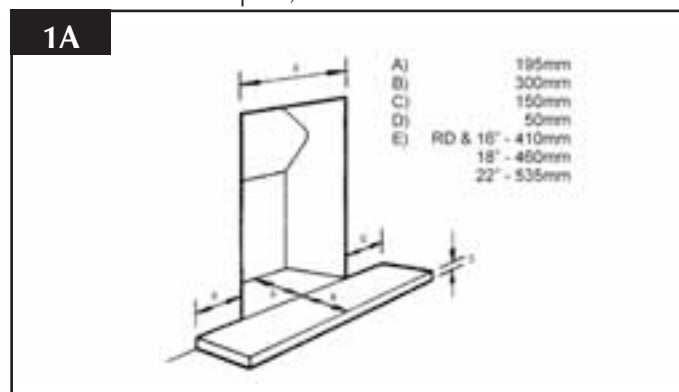

INSTALLATION INSTRUCTIONS

INSTALLATION

IMPORTANT: ENSURE THAT THE APPLIANCE IS CORRECTLY ADJUSTED FOR THE GAS TYPE AND CATEGORY APPLICABLE IN THE COUNTRY OF USE. REFER TO DATABADGE AND TECHNICAL SPECIFICATIONS AT THE FRONT OF THE BOOKLET. FOR DETAILS OF CHANGING BETWEEN GAS TYPES, REFER TO SECTION 33.

1. CONTROL UPGRADE

- 1.1 Your fire is fitted with a control valve that can be easily upgraded to battery powered remote control. This upgrade can be fitted by anyone capable of simple DIY jobs and requires no special training. This upgrade can be obtained through your local Gazco stockist.
- 1.2 **STANDARD REMOTE CONTROL** This remote control can control the fire after the pilot has been lit. It can turn the main burner on and regulate it from low through to high and back again. It can turn the main burner off leaving the pilot burning. GAZCO PART NUMBER 8455.
- 1.3 **IMPORTANT** - there is a thermostatic version of the upgrade but this is NOT SUITABLE for open flame fires.

2. SAFETY PRECAUTIONS

- 2.1 This appliance must be installed in accordance with the rules in force, and used only in a sufficiently ventilated space. Place read all instructions before installation and use of this appliance.
- 2.2 These instructions must be left intact with the user.
- 2.3 Do not attempt to burn rubbish on this appliance.
- 2.4 In your own interest, and those of safety, this appliance must be installed by a competent person in accordance with local and national codes of practice. Failure to install the appliance correctly could lead to prosecution.
- 2.5 Keep all plastic bags away from young children.

3. UNPACKING

- 3.1 Remove the appliance from its packaging, and check that it is complete and undamaged.
- 3.2 Put the loose ceramic parts to one side so that they are not damaged during installation.

4. INSTALLATION - RADIANT FIRES

- 4.1 Fix the rear leg strap. See diagram 1.

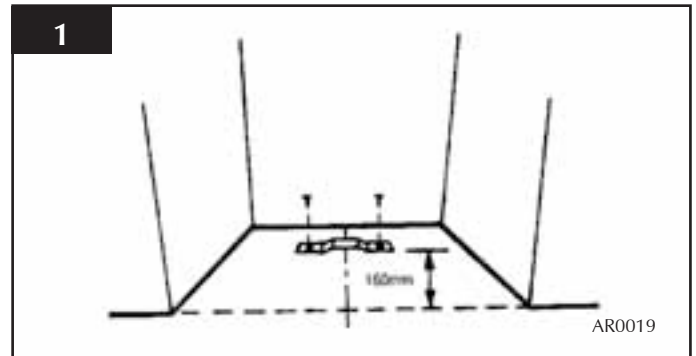

- 4.2 Position the fire with the rear leg fully engaged under the rear leg strap. Fasten the front legs using the fixings supplied.
- 4.3 "HAVE YOU PURGED THE GAS SUPPLY PIPES". This is essential to expel any foreign matter that might get blown into the valve assembly causing blockages.
- 4.4 Connect the 8mm gas supply pipe to the fire. See diagram 2& 3.

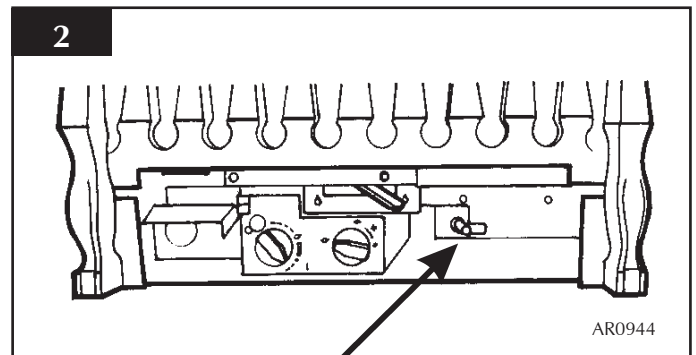

- 4.5 If the isolation tap is to be fitted under the fire, the GAZCO GC0060 provides a neat and easy solution. See diagram 3A.

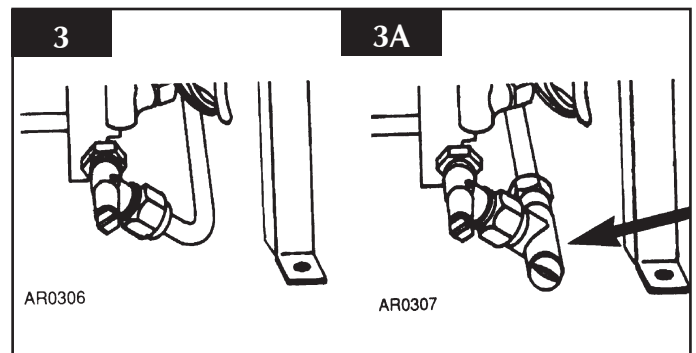

- 4.6 Check the gas connections to the fire are sound. Light the fire and check all joints on the appliance.
- 4.7 Check the appliance running pressure is correct. See databadge.

INSTALLATION INSTRUCTIONS

INSTALLATION

4.8 Fit the fret to the fire front using two screws. See diagram 4.

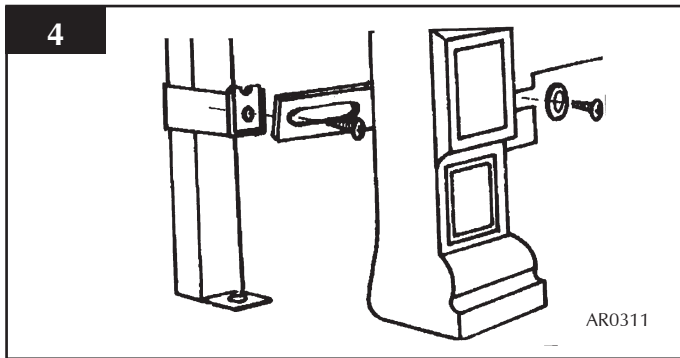

5. INSTALLATION - CONVECTOR FIRES

5.1 Make any necessary alterations to fireplace opening. Ensure that the lintel does not obstruct the flue outlet into the flue, and that there is a clear space for debris of at least 90mm. See diagram 5.

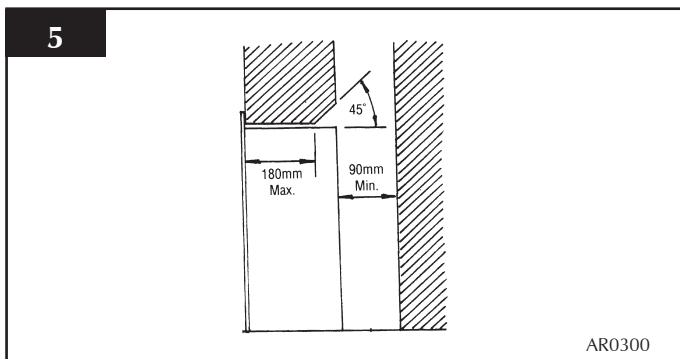

5.2 Gas pipe entry must be through one of the holes in the rear of the convector box. See diagram 6 & 7.

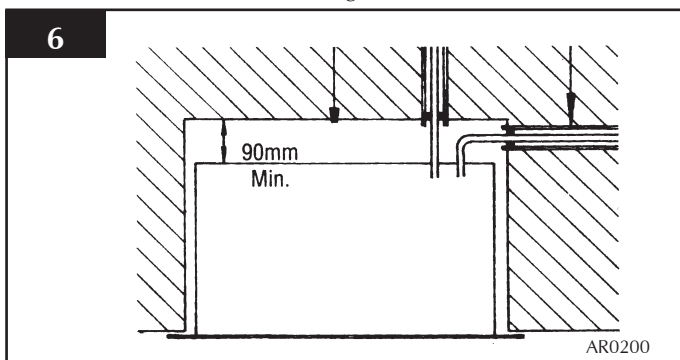

Note: Gas pipes passing through masonry must be protected.

5.3 If the isolation tap is to be fitted under the fire, the GAZCO GC0060 provides a neat and easy solution. See diagram 7A.

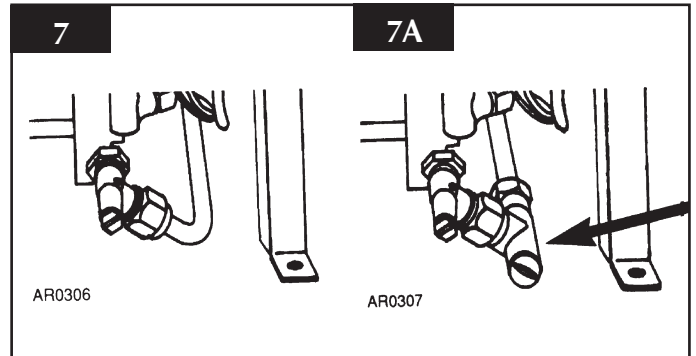

5.4 Remove the fire assembly (see diagram 9), and offer the convector box into the opening, checking that it fits squarely. Mark the fixing holes and the gas pipe entry positions. See diagram 8.

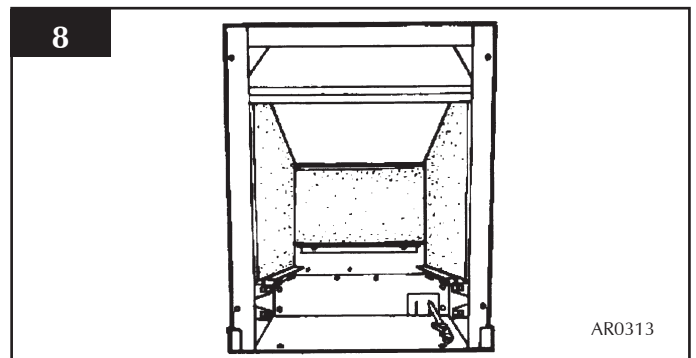

5.5 Fit the gas pipe into position, ready for passing into the convector box, ensuring enough remains to connect to the fire.

5.6 Carefully fit the convector box, feeding the piping through into the box. Secure the box to the wall, through the flange or base ensuring that the box is square in the opening. Any undulations or gaps between the convector box and the wall should be filled with a non-combustible material. Do not use silicone as it makes future removal almost impossible.

5.7 Refit the fire assembly and front air guide back into the convector box. See diagram 9.

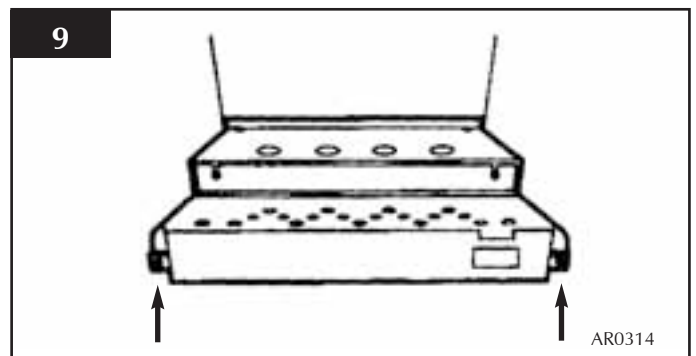

5.8 **HAVE YOU PURGED THE GAS SUPPLY PIPES.**

This is essential to expel any foreign matter that might get blown into the valve assembly causing blockages.

INSTALLATION INSTRUCTIONS

INSTALLATION

5.9 Connect the 8mm gas supply pipe to the fire. See diagram 10.

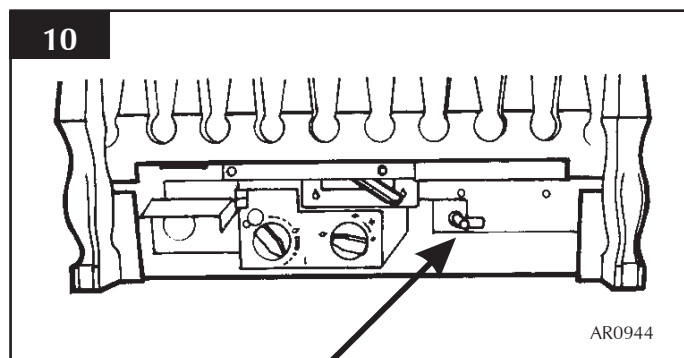

5.10 Check the gas connections to the fire are sound. Light the fire and check all joints on the appliance.

5.11 Check the appliance working pressure is correct. See databadge.

5.12 Fit the fire trim to the convector box. See diagram 11.

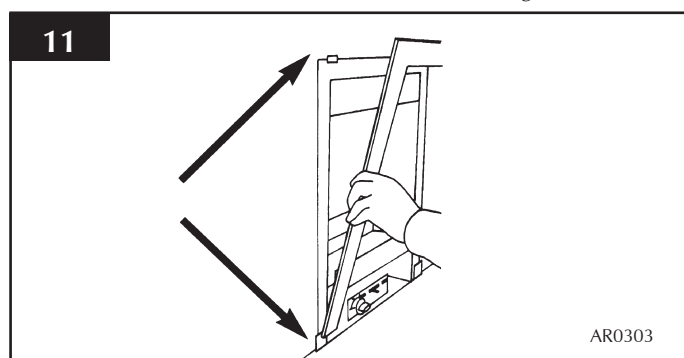

5.13 Fit the fret to the fire front using the two securing screws. See diagram 12.

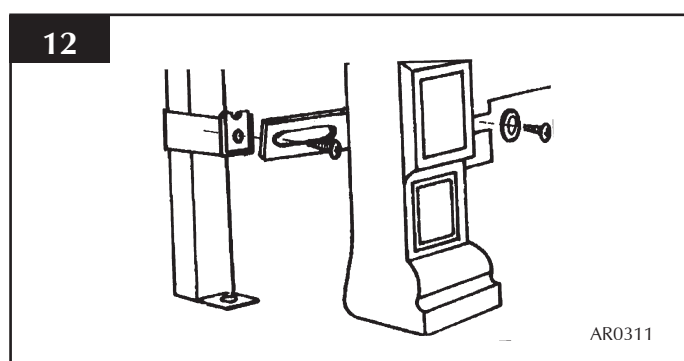

5.14 If the appliance is fitted with an alternative Gazco front please refer to the separate leaflet supplied with the front.

6. ARRANGEMENT OF FUELBED COMPONENTS

ADVICE ON HANDLING AND DISPOSAL OF FIRE CERAMICS

The fuel effect and side panels in this appliance are made from Refractory Ceramic Fibre (RCF), a material which is commonly used for this application.

Protective clothing is not required when handling these articles, but we recommend you follow normal hygiene rules of not smoking, eating or drinking in the work area and always wash your hands before eating or drinking.

To ensure that the release of RCF fibres are kept to a minimum, during installation and servicing a HEPA filtered vacuum is recommended to remove any dust accumulated in and around the appliance before and after working on it. When servicing the appliance it is recommended that the replaced items are not broken up, but are sealed within heavy duty polythene bags and labelled as RCF waste.

RCF waste is classed as stable, non-reactive hazardous waste and may be disposed of at a licensed landfill site.

Excessive exposure to these materials may cause temporary irritation to eyes, skin and respiratory tract; wash hands thoroughly after handling the material.

NOTE: CERAMIC PARTS ARE FRAGILE.

6.1 Position the flame baffle on the rear of the tray. See diagram 13 arrow B.

6.2 Position the front coal, make sure it sits flat onto the burner skin. See diagram 13 arrow C.

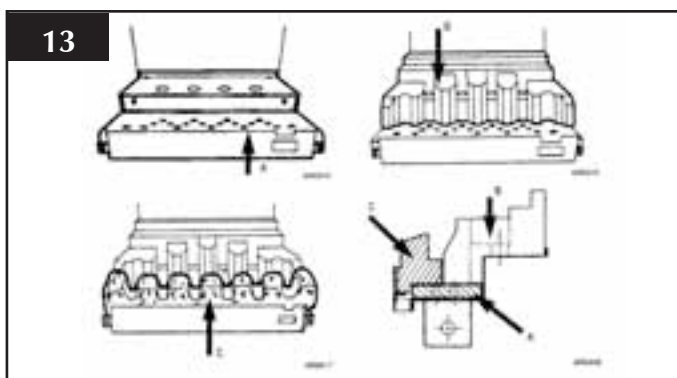

6.3 Place the coals following the appropriate diagrams and instructions

16" AND REDUCED DRAUGHT COAL LAYOUT

6.4 Curved fronts (Holyrood and Richmond) -place 5 large coals onto the front coal moulding ensuring that they rest against the front, place 2 small coals on to the front coal, 1 at each end. See diagram 14.

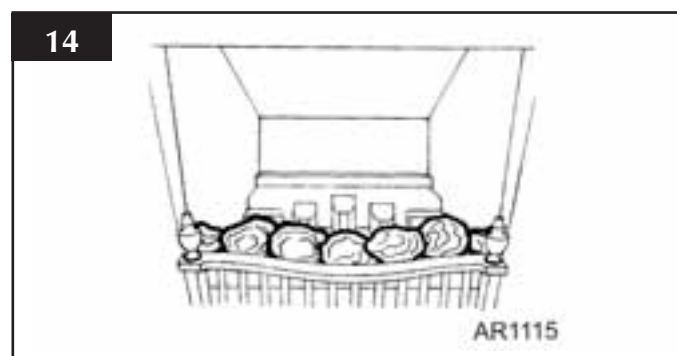

INSTALLATION INSTRUCTIONS

INSTALLATION

6.5 Flat fronts (All others) - Place 3 large coals and 4 small coals onto the front coal moulding ensuring that they rest against the decorative front, these should run intermittently small, large, small etc. See diagram 15.

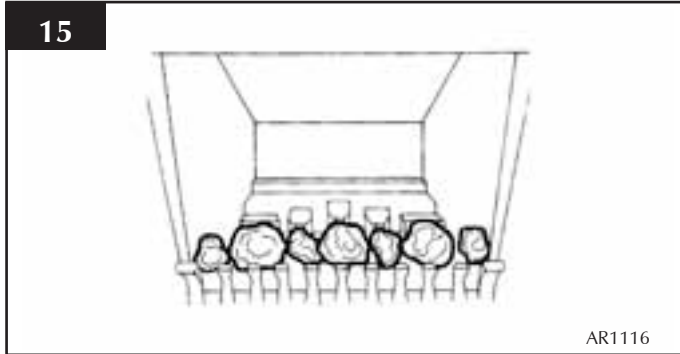

6.6 Place 5 large coals onto the flame baffle fingers. See diagram 16.

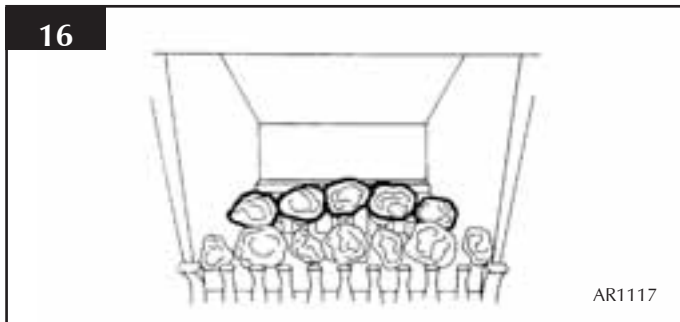

6.7 Place 4 large coals so that they form a bridge between the other 2 rows, and 2 small coals, 1 at each end. Place 4 large coals at the back of the fire. See diagram 17.

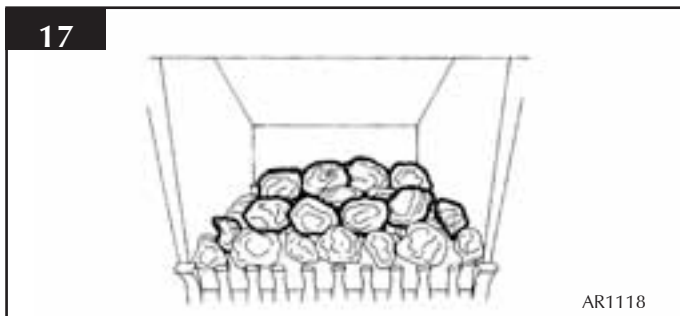

6.8 Place the remaining 4 small coals on top of the others so that they form a bridge between the second and third rows. See diagram 18.

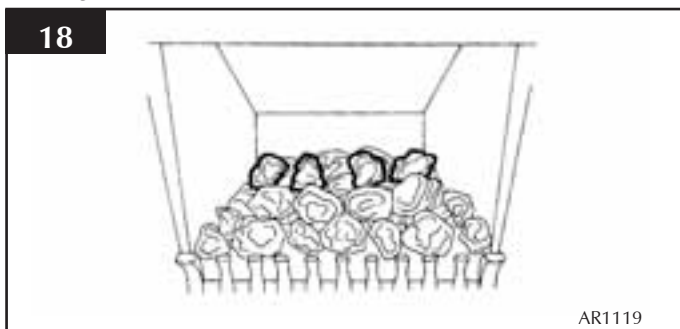

18" COAL LAYOUT

6.9 Curved fronts (Holyrood) - place 6 large coals onto the front coal moulding ensuring that they rest against the front, place 2 small coals on to the front coal, 1 at each end. See diagram 19.

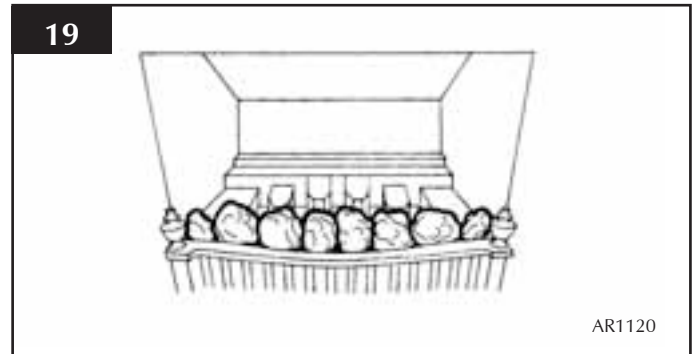

6.10 Flat fronts (All others) - Place 4 large coals and 4 small coals onto the front coal moulding ensuring that they rest against the decorative front, these should run intermittently small, large, small, with 2 large in the centre. See diagram 20.

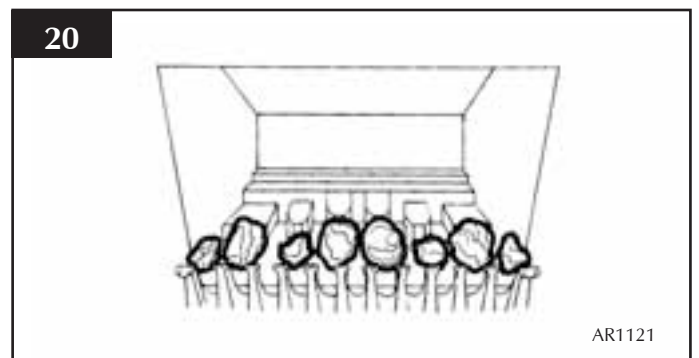

6.11 Place 6 large coals onto the flame baffle fingers. See diagram 21.

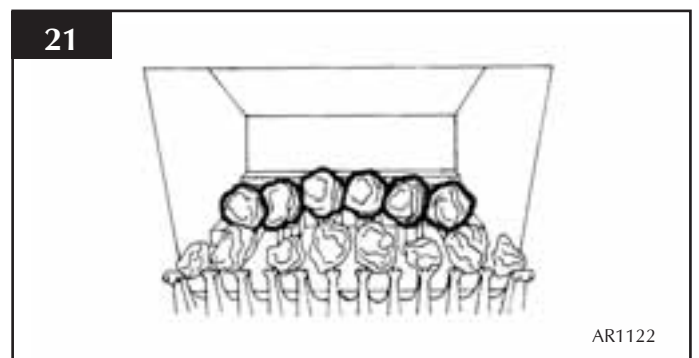

INSTALLATION INSTRUCTIONS

INSTALLATION

6.12 Place 5 large coals so that they form a bridge between the other 2 rows, and 2 small coals, 1 at each end. Place 5 large coals at the back of the fire. See diagram 22.

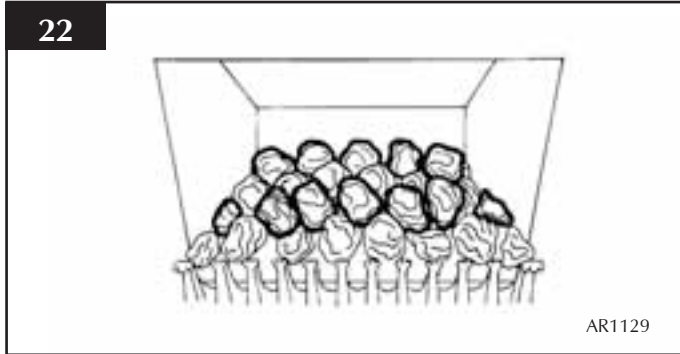

5.13 Place the remaining 5 small coals on top of the others so that they form a bridge between the second and third rows. See diagram 23.

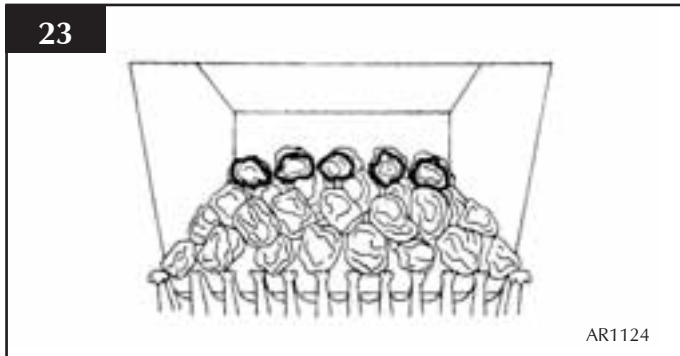

22" COAL LAYOUT

5.14 All fronts - place 8 large coals onto the front coal moulding ensuring that they rest against the front, place 2 small coals on to the front coal, 1 at each end. See diagram 24.

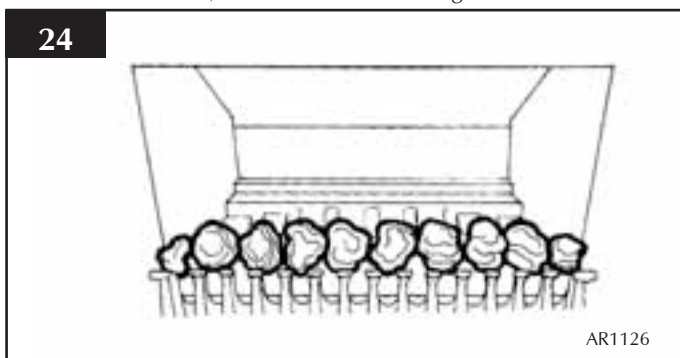

5.15 Place 8 large coals onto the flame baffle fingers. See diagram 25.

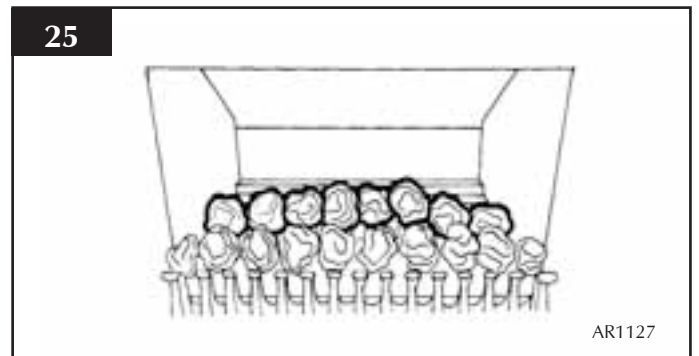

5.16 Place 7 large coals so that they form a bridge between the other 2 rows, and 2 small coals, 1 at each end. Place 6 large coals at the back of the fire. See diagram 26.

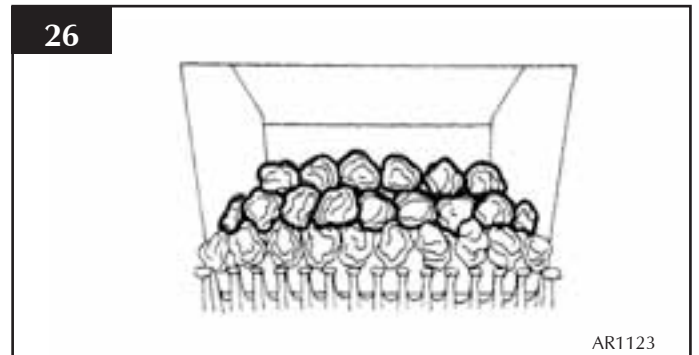

6.17 Place the remaining 6 small coals on top of the others so that they form a bridge between the second and third rows. See diagram 27.

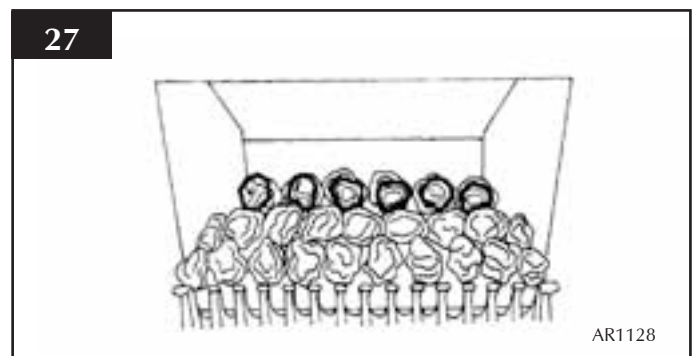

7. LIGHTING

7.1 Full instructions are given in the Users Section.

INSTALLATION INSTRUCTIONS

COMMISSIONING

1. COMMISSIONING

- 1.1 Close all windows and doors to the room, check all controls, and allow fire to burn on maximum for 5 minutes. Test for spillage of flue products using a smoke match. For standard VFC fires, pass the lighted smoke match along the top front edge just inside the opening or canopy. For the RD VFC only, hold the lighted smoke match centrally inside the flue opening. See diagram 1 for Radiant fires and 2 for Convector fires.

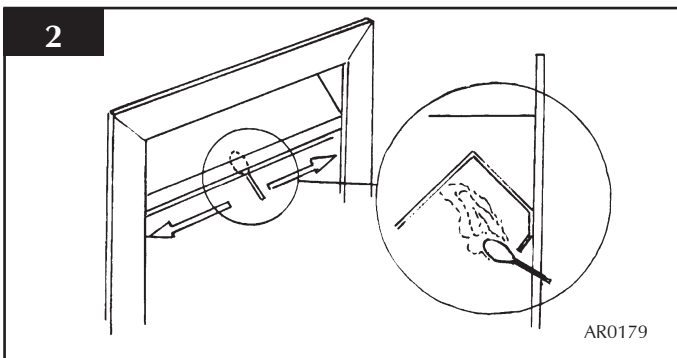
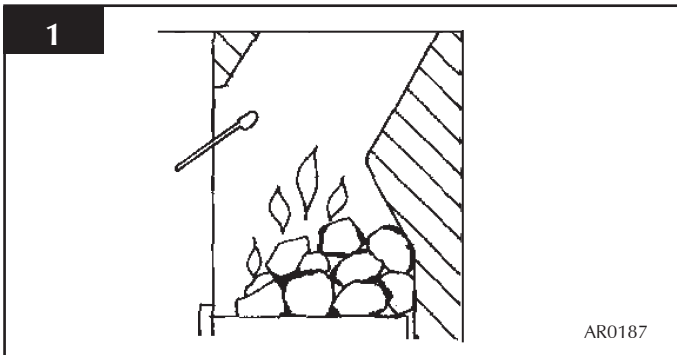

- 1.2 If the fire spills, run for a further 10 minutes and re-check. If there is still spillage, disconnect the fire and seek expert advice.
- 1.3 If there are extractor fans in the room or adjacent rooms, the spillage test must be repeated with the extractors running on maximum.
- 1.4 For RD VFC: If spillage is detected and no air vent is fitted in the room, re-check for spillage with a window slightly open. If this cures the spillage, it will be necessary to fit a vent.

IF SPILLAGE PERSISTS, DISCONNECT THE APPLIANCE AND SEEK EXPERT ADVICE.

For future reference record the installation details on the commissioning sheet on page 4 of these instructions.

INSTALLATION INSTRUCTIONS

SERVICING REQUIREMENTS

This appliance must be serviced at least one a year by a competent person.

1. SERVICING REQUIREMENTS

- 1.1 As part of the annual service, the space behind the convector must be inspected for any debris, which may have fallen down the chimney.
- 1.2 Remove the gas fire from the convector as detailed in section 4
- 1.3 Remove the convector box from the wall, see section 5 in Installation.
- 1.3 Inspect the space behind the convector for debris and the condition of the chimney, the flue flow test should be carried out now. Remove any debris and carry out any necessary remedial work.

2. FAULT FINDING

This is for use only by qualified Installers and Service Engineers.

Note: Many problems can be attributed to poor pilot flame length caused by blocked jets as the orifice is very small. If the flame length is much shorter than that shown in the diagram, the pilot may have to be changed. See diagram 7.

It is always worth using the nozzle of a vacuum cleaner over the end of the pilot to ensure that it has no debris within it. In addition, many ignition problems are caused by incorrect spark gap, ensure it is set as in diagram 7.

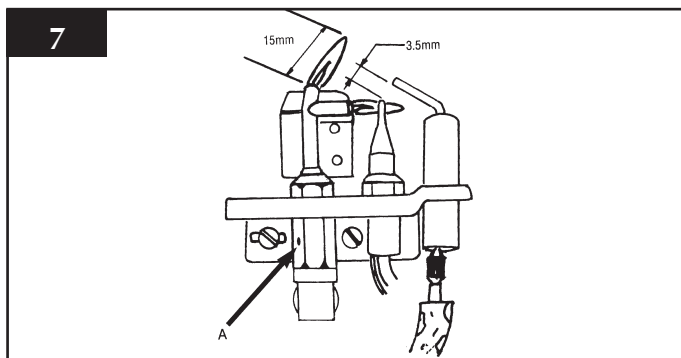

FLAME FAILURE FUNCTIONAL CHECK

PILOT WILL NOT STAY LIT OR FIRE GOES OUT

If the appliance goes out in use continually, this may mean that the oxygen depletion sensor has been activated. The appliance should not be used until the cause has been found and rectified.

Ensure there is no debris around the pilot assembly, e.g. coal, soot, etc.
Check for fluff in the pilot aeration hole. See diagram 7.

Light the pilot and keep the control knob pushed in at least 10 seconds before letting go

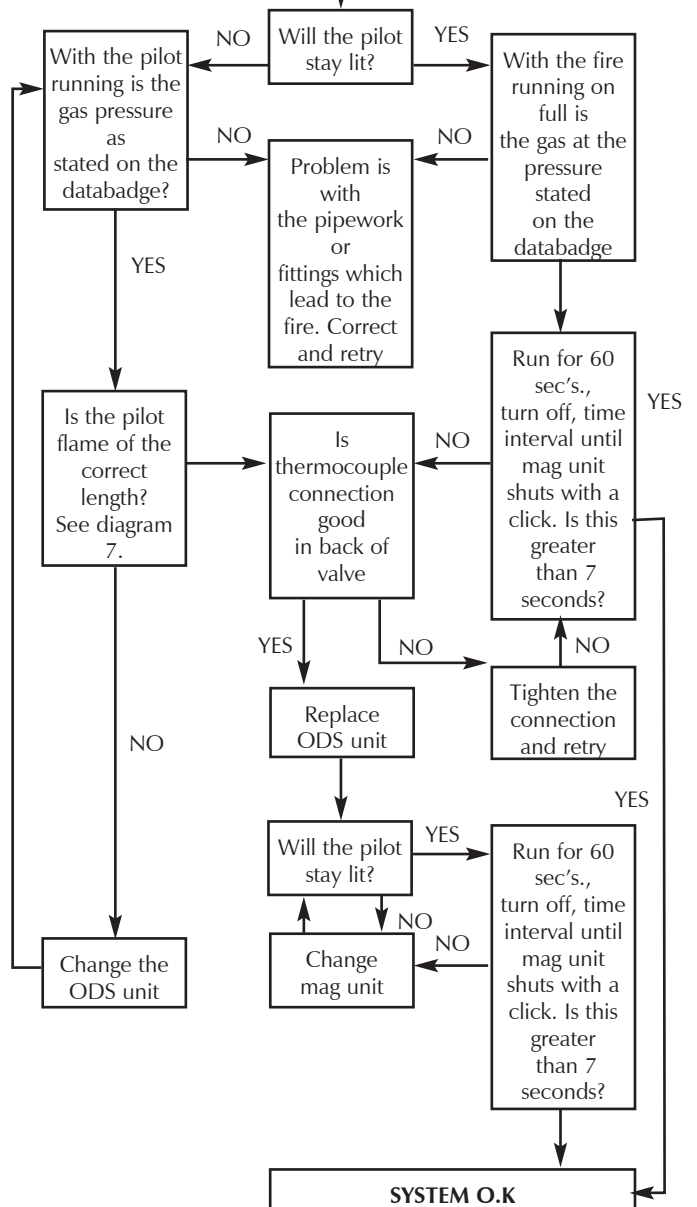

FAULT FINDING

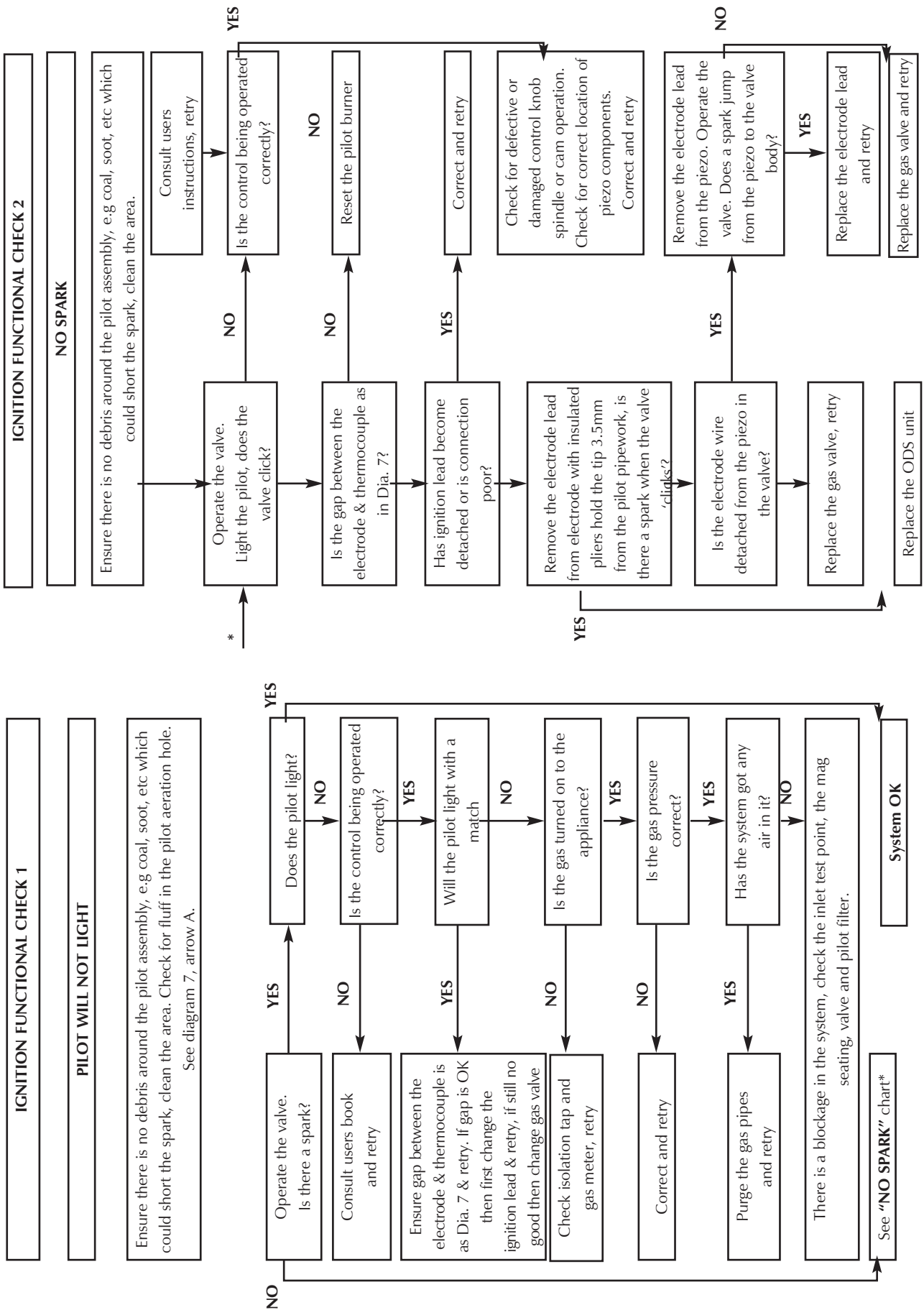

INSTALLATION INSTRUCTIONS

REPLACING PARTS

The following part can be serviced without removing the fire.

2. IGNITION LEAD

2.1 Turn off the gas supply at the isolation device.

2.2 Remove the fret. See diagram 1.

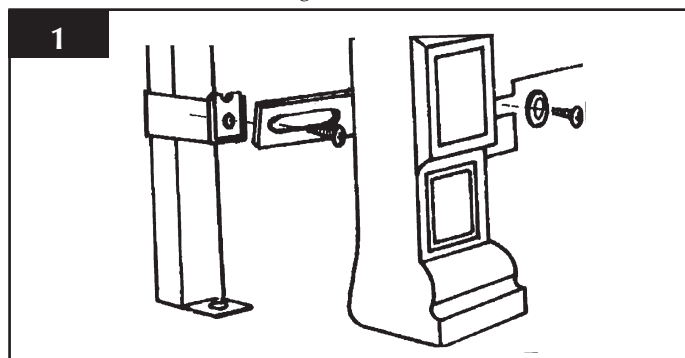

2.3 Undo the single screw that secures the left hand side of the control cover. See diagram 2.

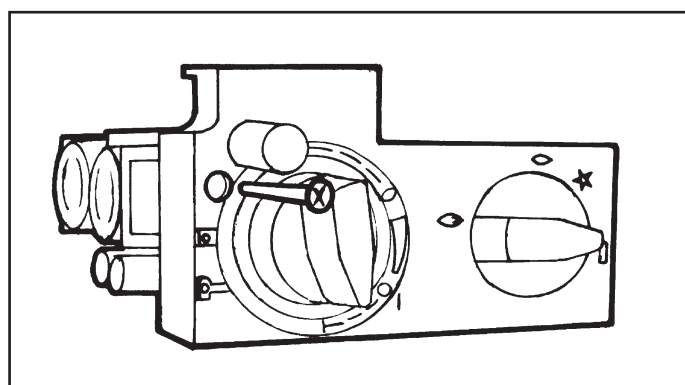

2.4 To release the right hand side of the control cover insert the narrow blade screwdriver into the slot shown in diagram 3, lever it gently and pull from the right hand side at the same time. The cover will now come off, there is a small cylindrical metal spacer inside the cover, this must be kept and replaced on the fixing screw during re-assembly.

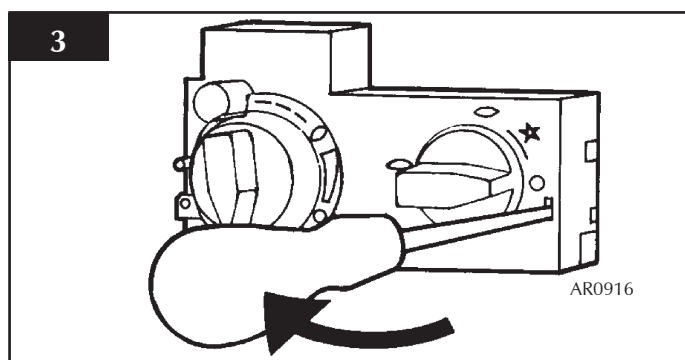

2.5 Disconnect the ignition lead from the gas valve and the pilot. See diagram 4 arrow A.

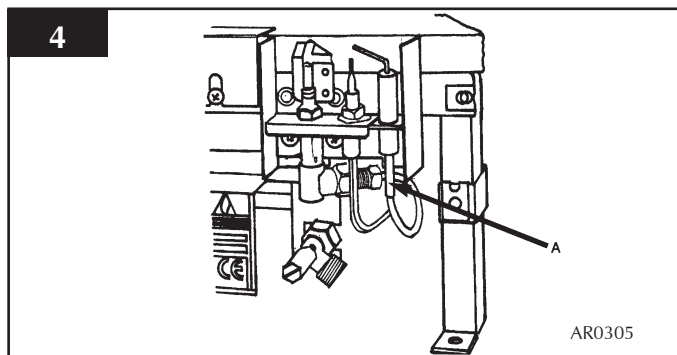

2.6 Replace with a new ignition lead following the same route as the old one. Replace the valve cover and the pilot assembly.

2.7 Check the operation of the new ignition lead.

2.8 Replace the fret.

3. PIEZO

3.1 The piezo assembly used on this appliance is not serviceable and is unlikely to fail.

4. THE FOLLOWING PARTS REQUIRE THE REMOVAL OF THE BURNER FROM THE CONVECTOR BOX .

- Turn the gas supply off at the isolation device.
- Disconnect the gas supply pipe from the pressure test elbow on the appliance.
- Undo the screws securing the fire. See diagram AR0314.
- Remove the fire for servicing.

INSTALLATION INSTRUCTIONS

REPLACING PARTS

5. ODS PILOT UNIT

Note: The pilot unit on the appliance is a non serviceable unit due to the complex nature of its manufacture. Replacement of the complete unit must be carried out when one of the following items becomes faulty:

- Pilot injector
- Ignition electrode
- Thermocouple

5.1 Carry out operations (a) to (d), section 4.

5.2 Gently pull the ignition lead off the electrode. See diagram 5 arrow A.

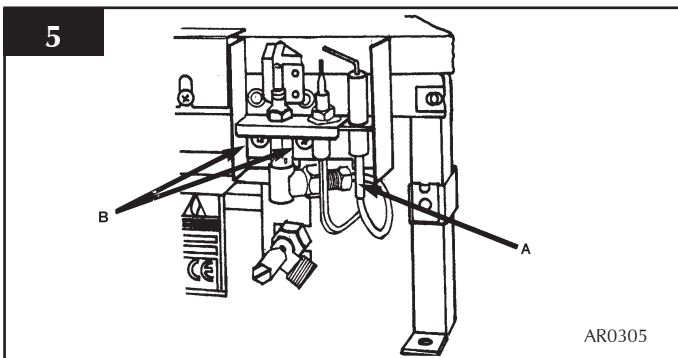

5.3 Remove the two screws securing the pilot assembly. See diagram 5 arrow B.

5.4 Undo the thermocouple connection at the back of the gas valve. See diagram 6 arrow A.

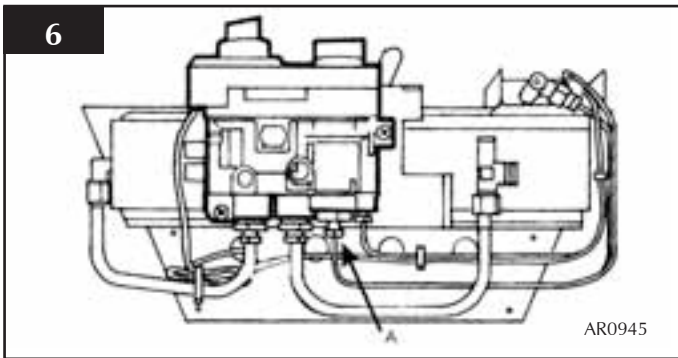

5.5 Replace with a new pilot assembly, set the spark gap. See diagram 7.

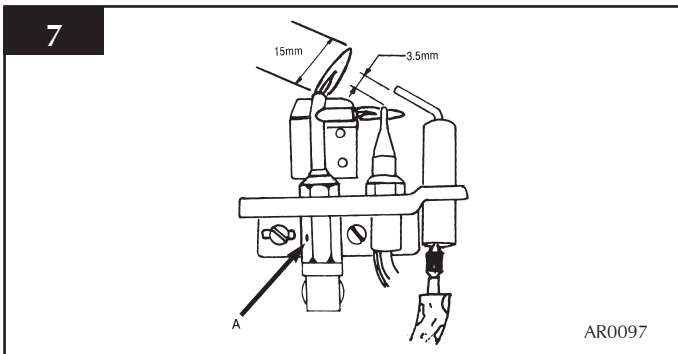

5.6 After reassembly, check for gas soundness and carry out a flame failure functional check details in the flow chart, especially the mag drop out time.

6. GAS VALVE

6.1 Turn the gas supply off at the isolation device.

6.2 Disconnect the 2x8mm and 1x4mm gas pipe fittings at the back of the gas valve and also disconnect the thermocouple, see diagram 8 arrow B.

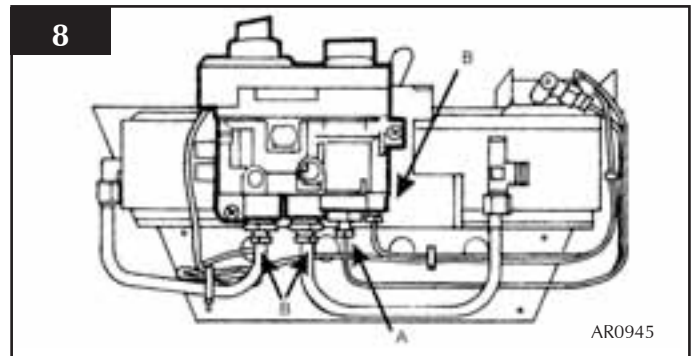

6.3 Undo the single screw that secures the left hand side of the control cover, see diagram 9.

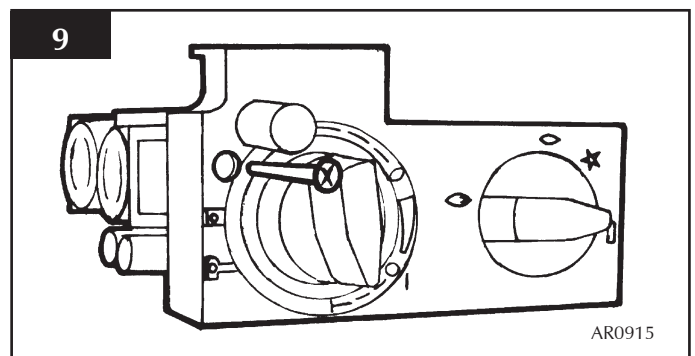

6.4 To release the right hand side of the control cover insert the narrow blade screwdriver into the slot shown in diagram 10, lever it gently and pull from the right hand side at the same time. The cover will now come off, there is a small cylindrical metal spacer inside the cover, this must be kept and replaced on the fixing screw during re-assembly.

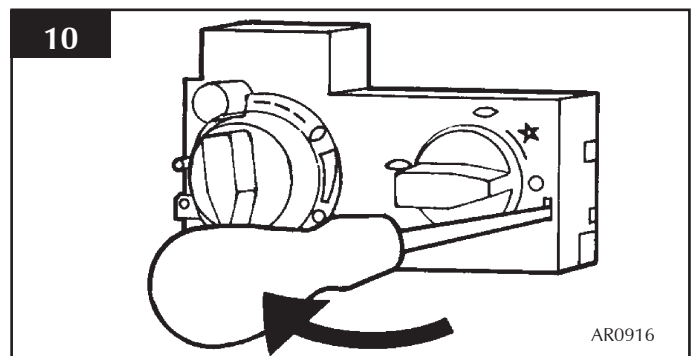

INSTALLATION INSTRUCTIONS

REPLACING PARTS

- 6.5 Disconnect the ignition lead from the gas valve, refer to section 27.
- 6.6 Undo the two bolts securing the gas valve to the appliance and remove the valve.
- 6.7 Replace in reverse order.
- 6.8 Check all joints for gas leaks, check operation of the thermocouple and ignition lead.

8. MAG UNIT

- 7.1 Carry out operations (a) to (d), section 4.
- 7.2 Undo the mag unit retaining nut at the back of the control valve. See diagram 11 arrow A.

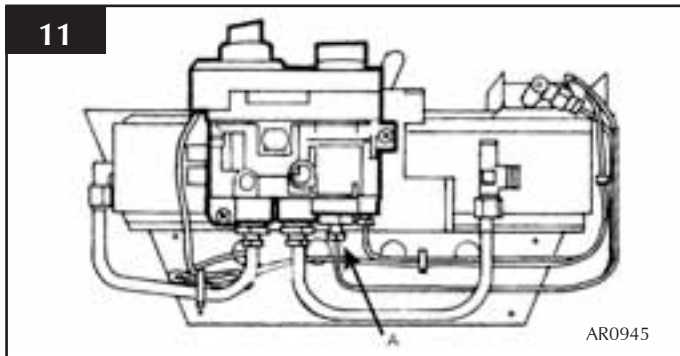

- 7.3 After removing the retaining nut, the mag unit can be tapped out and a replacement fitted.
- 7.4 Replace the mag unit retaining nut and tighten. Note - this is a gas-tight seal.
- 7.5 Replace the thermocouple and check for gas leaks.
- 7.6 After reassembly, carry out the flame failure functional check as detailed in the flow chart, especially the mag unit drop out time.

9. MAIN INJECTOR

- 8.1 Carry out operations (a) to (d), section 4.
- 8.2 With the fire removed, undo the injector compression nut (see diagram 6 arrow C), pull the pipe clear of the injector body.

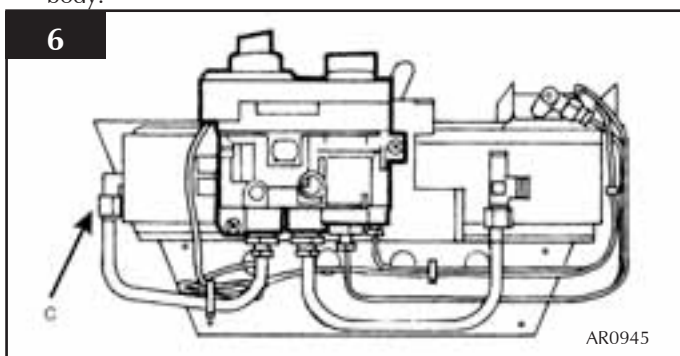

- 8.3 Rotate the injector until it is fully removed.
- 8.4 Replace with the correct replacement injector. When ordering, always state the model, gas type and serial number.
- 8.5 Reassemble and turn the gas supply on, check for any leaks

10. CHANGING BETWEEN GAS TYPES

The following parts must be changed when converting an appliance from one gas type to another:

- Main injector
 - Pilot assembly
 - Aeration adjuster
 - Control valve
 - Data Badge
- Refer to Gazco for a Conversion Kit

Note: The control valve will be set for the particular Appliance. In addition a new databadge will need to be ordered. In all instances, when ordering new parts, be sure to quote the appliance type and serial number.

Use only genuine Gazco replacement parts. Non-standard components will invalidate the guarantee and may be dangerous.

SPARES PARTS LIST

SPARES PARTS LISTS

MANUAL FIRES	RD	16	18	22
CERAMIC PARTS				
Front Coal LH	CE0151		CE0152	CEO153/54
Flame Baffle	CE0119		CE0120	CEO121
Burner Skin	CE0155		CE0156	CEO157
Coal Set	CE0394		CE0395	CEO396
Convector Side Cheek LH	CEO158			
Low Convector Side Cheek LH	CEO160			
Convector Side Cheek RH	CEO159			
Low Convector Side Cheek RH	CEO161			
NATURAL GAS PARTS				
Main Injector	IN0007	IN0005	IN0043	IN0042
Pilot Assembly		PI0036		PI0044
Aeration Adjuster	GZ3461		GZ3463	GZ3464
Gas Valve	GC0088 - Preset for Nat. Gas*			
LPG GAS PARTS				
Main Injector	IN0025	IN0001	IN0002	IN0023
Pilot Assembly		PI0037		PI0045
Aeration Adjuster	GZ3465	GZ3466		GZ3467
Gas Valve	GC0088 - Preset for LPG Gas*			
MISCELLANEOUS				
Ignition Lead	GC0090			
Mag Unit	GC0092			
Control Cover	GC0087			
Upgrade Kit	8455			

*Please note: The gas valve is factory preset-please consult Gazco for advise stating the model number and gas type.

SERVICE RECORDS

1ST SERVICE

Date of Service:.....
Next Service Due:.....
Signed:.....

3RD SERVICE

Date of Service:.....
Next Service Due:.....
Signed:.....

5TH SERVICE

Date of Service:.....
Next Service Due:.....
Signed:.....

7TH SERVICE

Date of Service:.....
Next Service Due:.....
Signed:.....

9TH SERVICE

Date of Service:.....
Next Due:.....
Signed:.....

2ND SERVICE

Date of Service:.....
Next Service Due:.....
Signed:.....

4TH SERVICE

Date of Service:.....
Next Service Due:.....
Signed:.....

6TH SERVICE

Date of Service:.....
Next Service Due:.....
Signed:.....

8TH SERVICE

Date of Service:.....
Next Due:.....
Signed:.....

10TH SERVICE

Date of Service:.....
Next Service Due:.....
Signed:.....

Gazco Limited, Osprey Road, Sowton Industrial Estate, Exeter, Devon, England EX2 7JG
Tel: (01392) 261999 Fax: (01392) 444148 E-mail: info@gazco.com

A member of the Stovax Group